

## HIGH TEMPERATURE OPTICAL FIBER SENSOR FOR ATMOSPHERIC REENTRY

E. Haddad<sup>1</sup>, R.V. Kruzelecky<sup>1</sup>, K. Tagziria<sup>1</sup>, B. Aissa<sup>1,5</sup>, Iain McKenzie<sup>2</sup>, A. Guelhan<sup>3</sup>, J.-M. Muylaert<sup>4</sup>,  
Mert Celinkin<sup>5</sup>, David Barba<sup>5</sup>

<sup>1</sup>MPB-Communications, Canada, <sup>2</sup>ESA-ESTEC, The Netherlands, country, <sup>3</sup>DLR, Cologne,  
Germany, <sup>4</sup>VonKarmen Institute, Belgium, <sup>5</sup>INRS-EMT, Canada

### SUMMARY

Atmospheric reentry transition is produced at hypersonic velocity and is accompanied by a sharp excessive heat load for a few minutes, on the exposed materials, leading to a temperature increase of more than 1000°C.

MPBC developed optical fiber sensors for such temperatures with special packaging optimizing between protective capability and fast thermal conductivity. The fiber sensors were calibrated with thermocouples first using standard oven, then with stationary plasma at Von Karman Institute (Belgium) followed by a test within a wind tunnel (1000°C, 8 Mach number) at DLR-Cologne.

To well monitor the fast heat fluxes in reentry a special ruggedized interrogation module (Interrogator) was developed with a data acquisition at 100 Hz., with a large memory capacity to save data during 1 hour, and a USB memory stick as back up. The Interrogator was validated for vacuum, thermal cycling and vibrations.

The sensors are based on Fiber Bragg Gratings (FBGs). These gratings undergo a decay and regeneration process the first time brought to temperature > 750°C. The regeneration is not a well understood phenomenon and if it is of physical or chemical origin. This is still an open question, addressed by different international teams. MPBC is collaborating with a university team (INRS-EMT), to understand the regeneration process.

Four lines of fibers with 6 FBG sensors on each line were integrated in ROTEX-T rocket, built by DLR, launched in August 2016. During the rollout to the launch stage, the passive fiber used as extension between the sensors and Interrogator, broke inside the engine. The sensors could not record any temperature, however the interrogator itself worked normally and the telemetry data was received as designed. The ROTEX-T payload part including the Interrogator, impacted the ground with a velocity of about 95 m/s. The housing of interrogator and memory stick box was nearly completely undamaged. All four fiber optic connectors were still attached. The internal memory card was removed and was completely undamaged. The card was still working normally and the flight data files were downloaded.

### I. INTRODUCTION

Atmospheric reentry transition is produced at hypersonic velocity and is accompanied by a sharp excessive heat load for a few minutes, on the exposed materials, leading to a temperature increase of more than 1000°C.

The need for in-flight research comes from the lessons learned from the past Mirka and IXV (ESA), and US (X-series, SpaceX, Blue-Origin) as well as other Japanese (Hyflex, Ortex) flight test programmes where system expertise was gathered through flight experimentation.

Materials with high aero-thermo-dynamics performance and characteristics are required to safely fly hypersonic aerospace vehicles, during re-entry. Thermal protection system (TPS) materials are used to shield hypersonic aerospace vehicles from the severe flow heating encountered during atmospheric entry. Two classes of materials have been proposed, the high-temperature ceramics and the super alloys.

### II. EXPERIMENTAL DEVELOPMENT

The experimental part included the development of the fiber sensor packaging, and building the interrogator, the validation of the sensors in stationary plasma at VKI (1100-1200°C) and in wind tunnel high temperature plasmas at DLR (8 Mach number, 1000°C) and qualification for the reentry environment and conditions. Then the system was integrated on Rotex-T rocket and the launch and reentry were performed in August 2016.

## II.A Fiber sensor

MPB developed optical fiber sensors based on Fiber Bragg Gratings, stable for temperatures up to 1000°C using gold coated fibers with special packaging optimizing between protective capability for the passive fiber and fast thermal conductivity on the sensor locations.

The FBGs undergo a decay and regeneration process the first time brought to temperature > 750°C. The fiber sensors were regenerated at 900°C as optimal temperature for regeneration (Fig.1), during a period of a few hours, then we calibrated the regenerated FBG response to temperature with thermocouples using standard cylindrical ceramic oven. A preliminary test confirmed the stability of the FBG intensity and Central WaveLength (CWL) of the sensors at 1000°C for 24 hours.

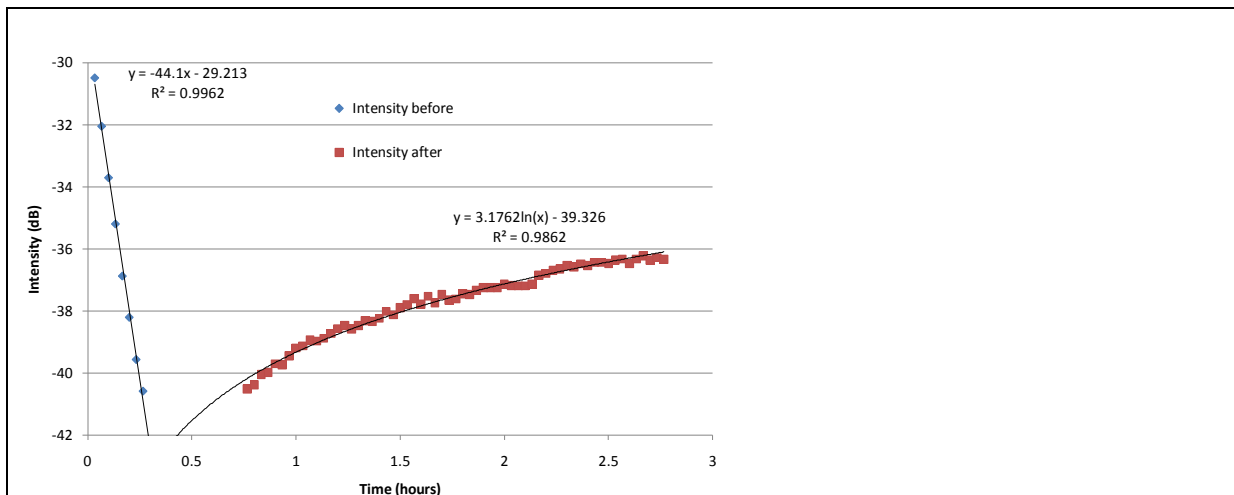

**Fig. 1: Evolution of Intensity of the FBG sensor set at 900 C during regeneration. The peak disappears for about half hour, before starting to be regenerated.**

The regenerated FBGs stay up to about 1350°C, however the fiber becomes fragile after the gold melts at about 1050°C. The regeneration is not well understood if it is a physical or chemical phenomenon. A collaboration with a university team (INRS-EMT) is addressing this issue [2].

## II.B Interrogator

To follow well the heat fluxes during reentry, a second generation interrogators were developed with data acquisition at 100 Hz. The 100 Hz interrogator hardware consists of two assemblies inside the enclosure - the Optical Assembly and the Electronic Assembly (Fig. 2). The Optical Assembly fits into the Optical Tray, which is formed into the bottom plate of the enclosure. All optical components, including optical fibers, are mounted and securely potted on the optical tray.

The Optical tray module consists of the Optical Source and the Optical Distribution lines, both of which sit in the Optical Tray. The Optical Source provides a tuned broadband source optical signal from 1525 nm to 1570 nm. The Optical Source includes a tunable Fabry Perot filter. A tuning voltage from 0 to 20V can be applied to the piezo actuator monitoring the mirror of the tunable Fabry Perot filter to sweep and adjust the optical transmission wavelength in the range 1520-1570. The Optical Source has a redundant parallel architecture, effectively providing two independent tunable optical sources - one for fiber optic sensors Line\_1 and Line\_3 and the other for fiber optic sensors Line\_2 and Line\_4. The two optical sources are pumped by two 980 nm laser diode pumps, with power split 50:50 to the two optical source lines. The Optical Distribution lines distribute the generated tuned broadband optical source to the external fiber optic sensors (Line\_1 to Line\_4).

The Electronic Assembly consists of the Electro-Optics Board and the Computing Board. The Electro-Optics Board provides the required tuning voltage and bias current to all the electro-optics components (such as the 980 nm pump laser diode and the tunable FP filter). It also provides signal conditioning circuits for the AD590 temperature sensors and photodiodes. The Computing Board takes care of data processing and communications.

The new Interrogator has four lines of six sensors each, in addition to a reference FBG inside the interrogator. To select the optimal packaging design of the fiber sensors, a series of fibers were prepared and tested in different small tubes of less than one mm output diameter. The optimal option was to install only one fiber within small thin stainless steel tube of 0.35/0.45 mm input/output diameters. This design permitted to follow fast transient with a thin wall and in the same time offering a wall strong enough to prevent the tube buckling.

Fig. 3 presents the overall software architecture of the 100 Hz interrogator. The software is arranged in two levels. The Functional Level includes the modules that control the physical units. The High level includes the Data Acquisition Module and the Communication Plug-in. In addition to the possibility of a continuous download of the temperature, the data is saved on the Interrogator memory and on a USB protected within a metallic box (Fig. 4).

The housekeeping parameters (interrogator temperature, laser diode temperature and power, Fabry Perot signal) were not kept in order to leave room for the 100 Hz data acquisition.

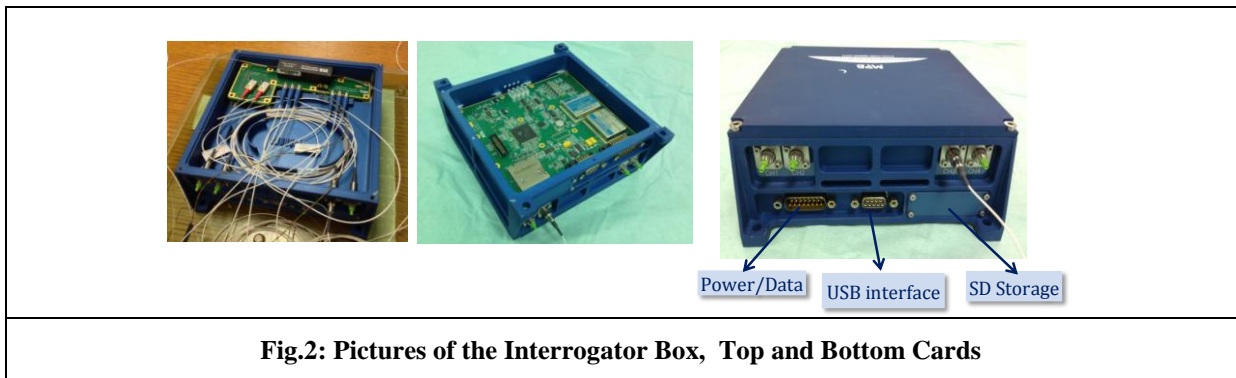

Fig.2: Pictures of the Interrogator Box, Top and Bottom Cards

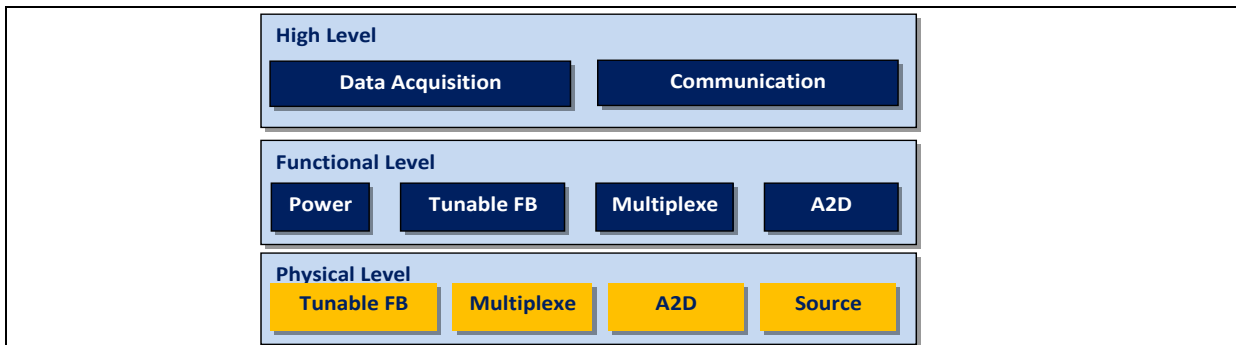

Fig. 3: Software Architecture

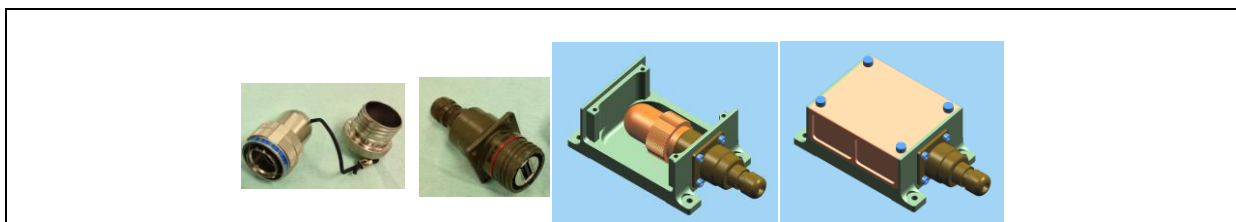

Fig. 4: Interrogator USB Box

II. C. Validation Test Von Karman Institute

Representative fiber sensor package was attached to one metallic (hastalloy 230) and one ceramic (C/SiC) prototypes. These packages were validated at Von Karman Institute – Belgium (VKI) plasmatron in a harsh environment similar to reentry plasma (Fig. 5). The plasma monitoring included: a) one thermocouple on the sample under test, close to the FBG packaging; b) an Infrared Camera, c) a pyrometer and d) a Heat Flux probe were measuring the plasma temperature and the heat flux, at the stagnation point.

Three Fiber interrogation modules were used, a) a Burleigh wavemeter, at 0.2 Hz, b) MPB-built, interrogator similar to that flying on Proba2 (launched in November 2009, and still completely functional) and c) a commercial FOS&S module.

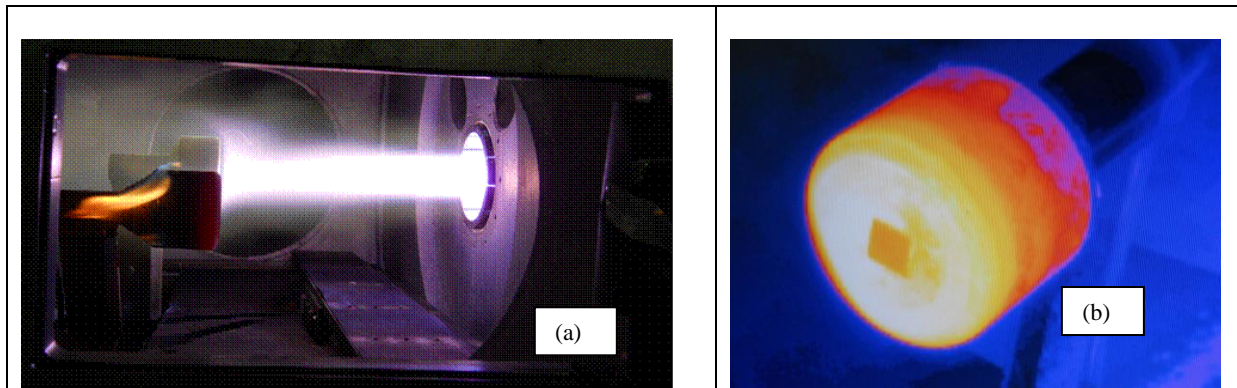

Fig. 5: Photograph of (a) the Plasma hitting the center of the probe with the FBG, the second adjacent is the heat flux probe, and (b) Image provided by the IR camera

The fiber sensors were heated and the fibers sensed temperatures of  $> 1100^{\circ}\text{C}$ . The gold coating melts at around  $1050^{\circ}\text{C}$ , and the fibers, without their protective coating could survive for five minutes before breaking under the vibrations. Fig.6 compares the results of the four instruments monitoring the temperature. The thermocouple and Fiber sensor (Burleigh measurements) provide very similar temperature, whereas, the Pyrometer and the IR camera temperatures are slightly higher, because they are in a slightly different location.

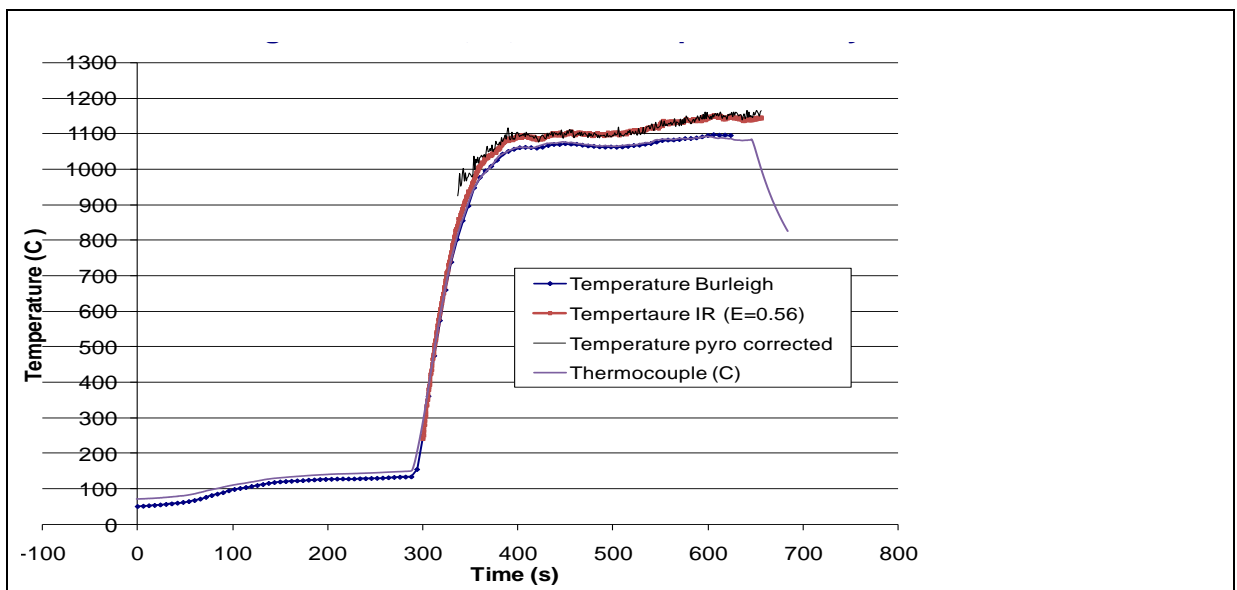

Fig. 6: Comparison of the plasma temperature as measured by the fiber sensors (Burleigh), Thermocouple Pyrometer and IR camera.

II. D. Validation Test in Wind Tunnel DLR-Cologne

The second validation of the fiber sensors was performed in a plasma wind tunnel at DLR (Cologne-Germany), simulating the reentry at 8 Mach number (3.5 km/s) and 1000°C (Fig.7). The device tested was a (C/SiC) tile, 150 mm x 250mm x 3 mm thick, similar to those installed on SHEFEX series reentry vehicles built by DLR. The tile embedded three (3) fiber lines, each of them containing three (3) sensors, in addition to a dozen of thermocouples (Fig. 8) that permitted to show the similarity between the transients and plateau temperatures seen by the Fiber sensors (100Hz acquisition) and those seen by the thermocouples (10 Hz acquisition).

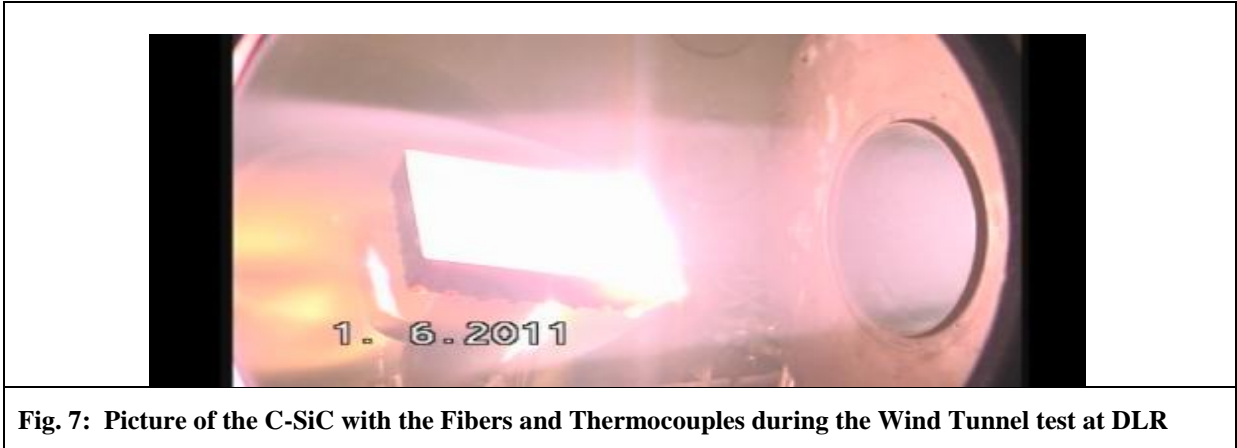

Fig. 7: Picture of the C-SiC with the Fibers and Thermocouples during the Wind Tunnel test at DLR

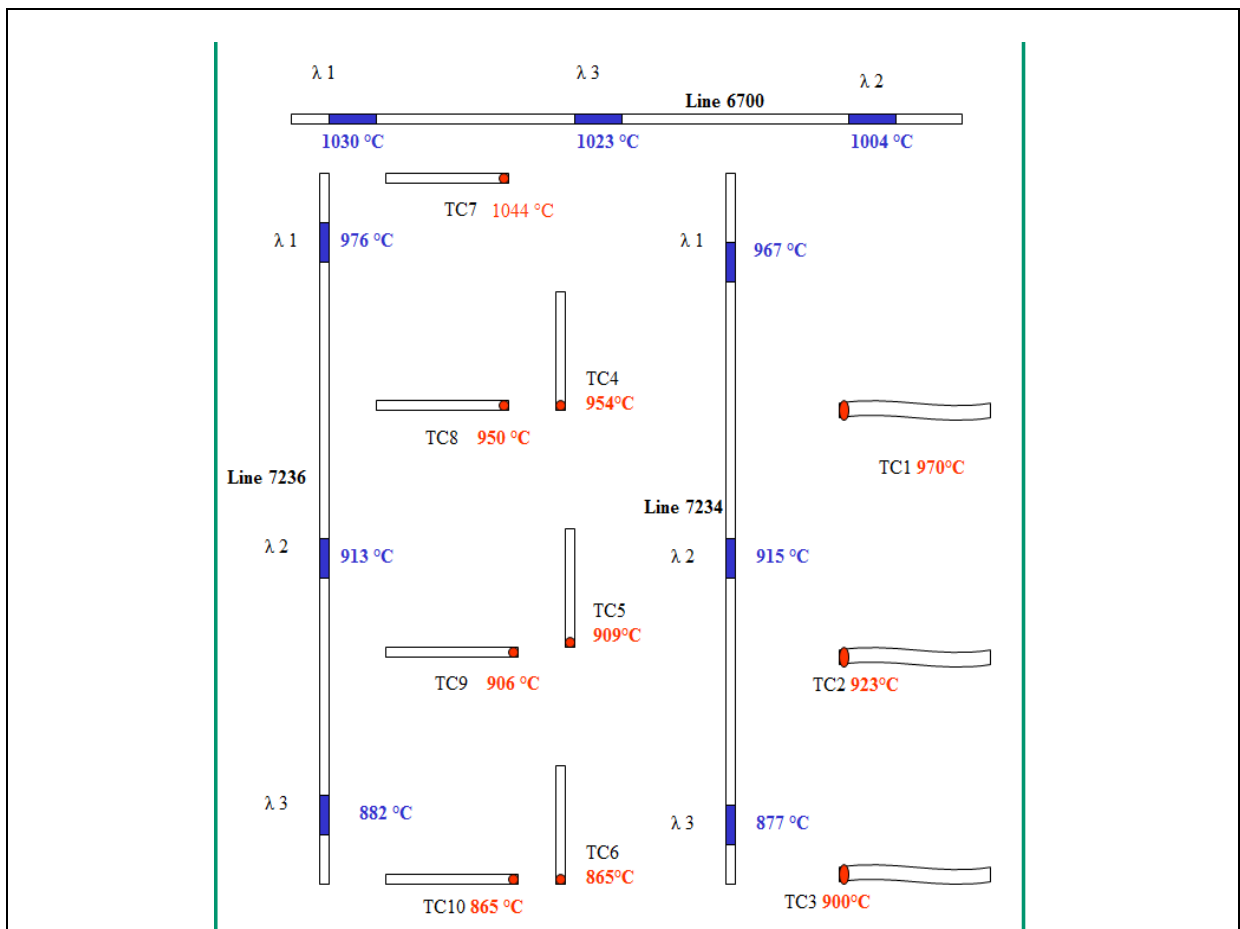
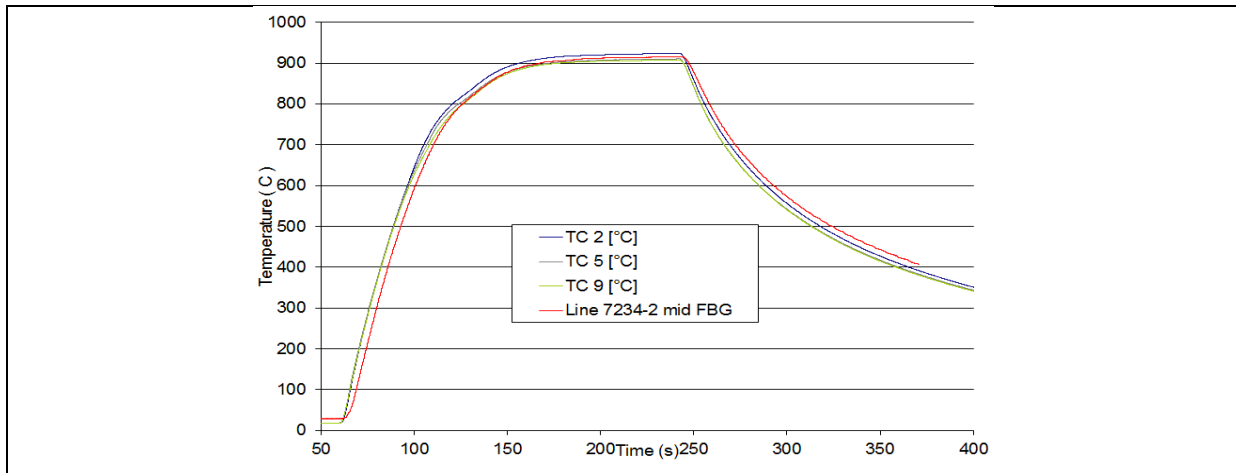

Fig. 8: Schematic showing the fiber sensors and thermocouples position on the C-SiC tile, with the temperature plateau value measured.

Fig. 9 presents the transient temperatures and plateau as seen by three thermocouples around an FBG sensors. The thermocouples are located in slightly deeper grooves (0.3 mm) compared to the fiber sensors, which makes them sense the transients slightly earlier. The response time of the FBG is faster than  $0.5 \mu\text{s}$ , as demonstrated in hypervelocity impacts study [3], which compares the fiber sensor response with the standard strain gauges sensors.

Some of the FBG were at  $1020^\circ\text{C}$  and  $1030^\circ\text{C}$  and stayed completely intact during all wind tunnel tests and temperature ramp down.



**Fig. 9: Temperature measured by one FBG and close by Thermocouples during the Wind Tunnel test**

### III RE-ENTRY EXPERIMENT ROTEX-T

Four (4) fiber lines with six (6) sensors each were prepared and integrated with the small stainless tubes. The sensors response were calibrated by fitting the wavelength changes with temperature to fourth order polynomials, to have accurate temperature within  $\pm 3^\circ\text{C}$  over the range  $-20^\circ\text{C}$  to  $+ 1000^\circ\text{C}$ .

The Interrogator and the fiber lines passed successfully the reentry qualification tests required for SHEFEX and ROTEX-T (Pressure-vacuum, thermal cycling and vibrations).

The fibers and Interrogator were integrated within ROTEX-T structure, tested and accepted by DLR (Fig. 10).

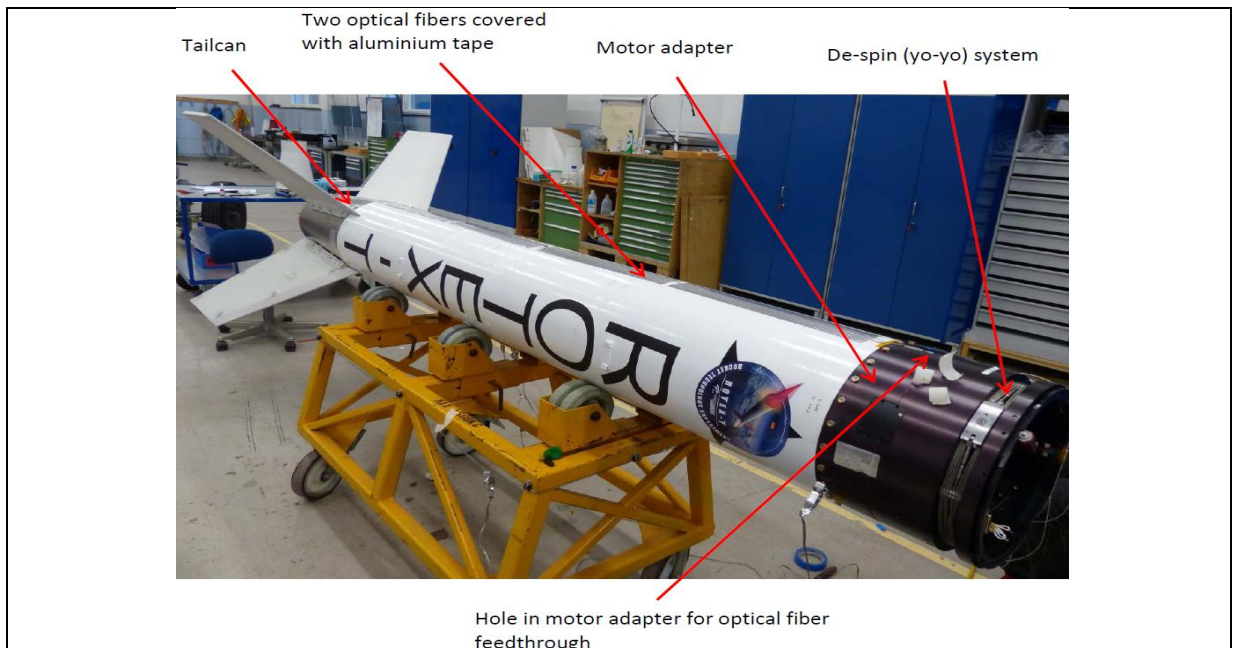

**Fig. 10: Fiber Sensor lines integrated within Rotex-T structure**

Only one RS422 port was designed for the Interrogator (called FOS by ROTEX team), the same port was used for the configuration/test-modes and the flight-mode for monitoring the payload during the flight. Fig. 11 illustrates the wiring diagram of the Interrogator (FOS) with ROTEX-T system.

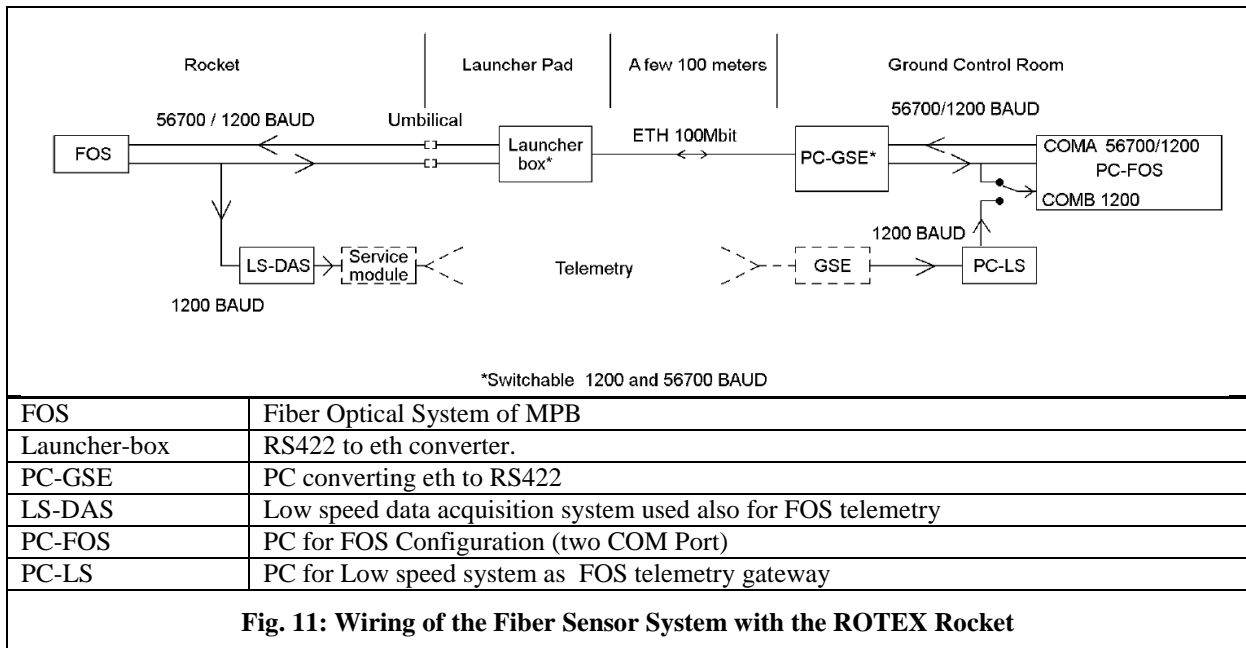

**Fig. 11: Wiring of the Fiber Sensor System with the ROTEX Rocket**

ROTEX-T rocket was launched in August 2016, the extension passive fiber between the sensors and the interrogator, broke inside the motor adapter during the rollout to the launch stage. It was not possible to have access to the launch stage for security reason.

During the complete flight, although it could not record any temperature, the interrogator itself worked normally and the telemetry data was received.

The ROTEX-T payload part impacted in the target area with a velocity of about 95 m/s. Fig.12 shows the Interrogator and USB after being mounted on the internal ROTEX-T set up, and as recuperated after the reentry experiment and on ground impact The housing of interrogator and memory stick box was nearly completely undamaged (some of the mounting feet were slightly deformed).

All four fiber optic connectors were still attached (Fig. 13), one was bent with no fiber, the other three had about 1.5 m fiber extension, probably this is where the fibers broke during to rollout.

The internal memory card was removed and was completely functional as tested by DLR. The card was still working normally and the flight data files were downloaded. The reading was correct although no temperatures could be recorded.

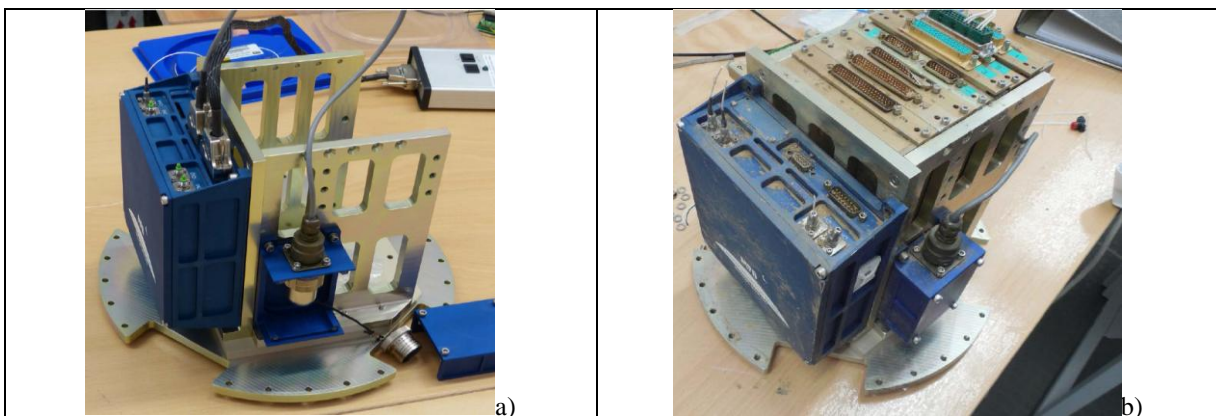

**Fig. 12: Interrogator enclosure and the USB box a) after attachment to ROTEX-T internal payload and b) as recuperated after the reentry and the on-ground impact**



**Fig. 13: Details of the Interrogator front with the connectors, three of them having their fibers still attached**

#### IV. CONCLUSION AND LESSONS LEARNED

MPB built and demonstrated the Fiber Optical Sensor system to measure the transient reentry temperatures at 100 Hz, although the fibers were broken inside the motor interface, the data acquisition and the telemetry performed as expected.

During validation tests, the fibers monitored the reentry equivalent plasmas in two environments: a) a stationary plasma with the fiber at the stagnation point at VKI plasmatron laboratory, with temperatures of 1100°C for almost five minutes without the gold coating protection, and b) at high temperature plasma of 1000°C in a wind tunnel at 8 Mach number.

The fiber sensor packaging is compatible with TPS representative ceramic (C/SiC) and HT metallic alloys. This packaging has a minimal intrusion, and provides an optimal sensor mechanical protection as well as a very fast thermal transfer. Various designs were proposed and simulated to comply with different requirements in terms of time response (less than 20 ms) and level of protection needed (thicker protective metallic tubes).

In future missions, MPB should keep in the memory the values of the housekeeping parameters such as interrogator temperature, laser diode temperature and power and the Fabry Perot signal, to follow their evolution during the mission. In particular, there is a reference FBG inside the interrogator for each line, it can provide at least the temperature of the interrogator during the readings, even after the fiber lines broke.

#### REFERENCES

- [1] Haddad E., Kruzelecky R., Zou J., Wong B.; McKenzie I., Muylaert J.; "Optic High Temperature Sensors for Re-Entry Vehicles in "The 6th European Symposium on Aero thermodynamics for Space Vehicles"; 3-5 November 2008 at Versailles, France; published in the ESA Proceedings Series, SP-659, January 2009; "6th European Conference on Aero-Thermo-Dynamics".
- [2] M. Celikin, D. Barba, B. Bastola, A. Ruediger, F. Rosei "Development of regenerated fiber Bragg grating sensors with long-term stability", Optics Express, vol. 24, (2016), p.21897-21907.
- [3] B. Aïssa, K. Tagziria, E. Haddad, W. Jamroz, J. Loiseau, A. Higgins, et al.; "The Self-Healing Capability of Carbon Fibre Composite Structures Subjected to Hypervelocity Impacts Simulating Orbital Space Debris," ISRN Nanomaterials Vol 2012 (2012), Article ID 351205, 16p. <http://dx.doi.org/10.5402/2012/351205>.